



Multi-Sequences for Paper Fall Devoid of Face Information in SFBC MIMO OFDM Systems

K.RAJESH
Department of ECE

M. D. AREEF
Department of ECE

K. SRIDHAR
Associate Professor,
Department of ECE

PRAKASH. J. PATIL
Head of the Department of ECE
Vijay Rural Engineering College, Nizamabad, Jntu-H

Abstract:

A novel unconventional multi-sequences scheme for the peak-to-average power ratio (PAPR) reduction in multi-input multi-output orthogonal frequency division multiplexing (MIMO-OFDM) systems with space frequency block coding (SFBC). The key idea of the proposed scheme is keeping the advantage of the SFBC structure to generate some alternative multi-sequences via combining the signals at different transmit antennas. Specifically, when the proposed scheme is employed in SFBC MIMO-OFDM systems with quadrature amplitude modulation (QAM), one of the big advantages is that the side information does not need to be sent to the receiver. Theoretical analysis and simulation results validate that the proposed scheme has the ability to provide large PAPR reduction, low bit error rate and low computational complexity without side information in SFBC MIMO-OFDM systems. This paper describes some of the important PAPR reduction techniques for multicarrier transmission including a novel alternative multi sequences (AMS) scheme and a low-complexity PAPR reduction scheme for SFBC OFDM MIMO systems. Compare and contrast of above techniques are discussed.

Keywords: A.M.S., M.I.M.O., O.F.D.M., P.A.P.R., S.F.B.C.

1. Introduction

Novel technologies such as orthogonal frequency division multiplexing (OFDM) and multiple input, multiple output (MIMO), can enhance the performance of the current wireless communication systems. The high data rates and the high capacity can be attained by using the advantages of these two technologies. Multiple transmit and receive antennas can be used to form multiple-input multiple-output (MIMO) channels to increase the capacity (by a factor of the minimum number of transmit and receive antennas) and data rate. A great disadvantage of the OFDM technique is its high Peak to Average Power Ratio (PAPR). High PAPR gives in-band and out of band distortion, also increases the complexity of the Analog-to-Digital (A/D) and Digital-to-Analog (D/A) converters. The high PAPR also lowers the efficiency of power amplifiers, since OFDM has a disadvantage of PAPR. Many solutions are proposed to reduce the high PAPR of the MIMO-OFDM systems. Space-time coding is a communications technique for wireless systems that realizes spatial diversity (and coding gain) by introducing temporal and

spatial correlation into the signals transmitted from different transmit antennas many space-time trellis and block codes have been proposed for flat fading channels. Most significantly, Altamonte in [3] discovered a very simple space-time block code (STBC) [4] for transmission with two antennas guaranteeing full spatial diversity and full rate Space-frequency coding basically extends the theory of space-time coding for narrowband flat fading channels to broadband time-variant and frequency selective channels. The application of classical space-time coding techniques for narrowband flat fading channels to OFDM seems straightforward, since the individual subcarriers can be seen as independently flat fading channels, thus SFBC MIMO OFDM is a more appropriate transmission scheme for multipath time-variant fading channels..

2. System Model

Orthogonal frequency division multiplexing (OFDM) is a well-known technique for transmission of high rate data over broadband frequency – selective channels [5]. One of the drawbacks of OFDM systems is high – peak – to – average power ratio (PAPR), which leads to the saturation of the high power amplifier. Thus, a high dynamic – range amplifier is needed, which increases the cost of the system. The frequency domain symbols of an OFDM frame is denoted by $X = [X(0), X(1) \dots \dots X(N_C - 1)]^T$, where N_C is the number of subcarriers. It is assumed that $X(k) \in C$ where C is the set constellation points. The vector $x = [x(0), x(1), \dots, x(N - 1)]^C$ contains the time - domain samples of the complex baseband OFDM signal as given by

$$x(n) = \frac{1}{\sqrt{N}} \sum_{k=0}^{N_C-1} X(k) e^{j2\pi nk/N}$$

Where $j = -1$, and N/N_C is the oversampling ratio. It is clear that $x = \text{IFFT}_N\{X\}$ where $\text{IFFT}_N\{\}$ is N – point inverse fast Fourier transform (IFFT) operation. The PAPR of the OFDM frame is defined by

$$\text{PAPR}(x) = \frac{\max_n\{|x(n)|^2\}}{E\{|x(n)|^2\}}$$

When N_C is large, based on the central limit theorem, the time domain samples have a Gaussian distribution; thus, they may have large amplitudes [7]. To overcome this problem, some algorithms have been proposed which reduce the PAPR of the baseband OFDM signal [7] – [12]. Some of these methods need side information (SI) to be transmitted to the receiver, such as partial transmit sequence [7],[8] and selected mapping (SLM) [9] – [11]. Using several transmitter antennas, one can improve the data rate or bit error rate (BER) of wireless systems. In spatial multiplexing systems, independent symbols are transmitted from several antennas, and this leads to the increase in data rate. A simplified

SLM method has been introduced for PAPR reduction of spatially multiplexed OFDM systems. If spatial diversity techniques are used in wireless systems with several transmitter antennas, the BER can be reduced. The space-time codes to achieve the full transmission diversity have been introduced in and. Through a combination of spatial diversity and OFDM techniques, a higher capacity can be achieved over broadband multipath fading wireless channels. Two possible combinations of spatial diversity and OFDM techniques are space-time-block-coded (STBC) OFDM and space-frequency-block- coded (SFBC) OFDM systems. Both combinations suffer from high- PAPR problem. In [13],

The clipping and differential scaling has been used for PAPR reduction in SFBC-OFDM systems

with two transmitter antennas, and an iterative method has been proposed to compensate for the effect of clipping noise at the receiver.

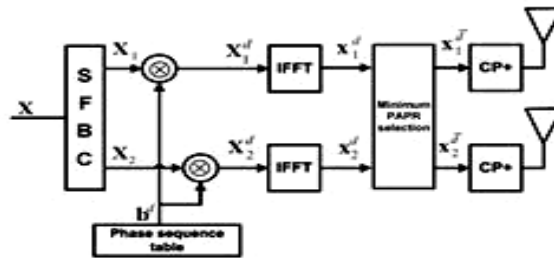

Fig. 1

Block diagram of SFBC – OFDM transmitter with two transmitter antennas and with SLM method for PAPR reduction.

2.1 Space Frequency Coding (SFC)

It is a frequency domain adaptation of renowned Space-time Block Coding (STBC) where encoding is done in antenna/ frequency domains rather than in antenna/time domains. STBC is also recognized as Alamouti coding [3]. The advantage of SFBC over STBC is that in SFBC coding is done across the subcarriers within the interval of OFDM symbol while STBC applies coding across the number of OFDM symbols equivalent to number of transmit antennas [5]. The operation of SFBC is carried out on pair of complex valued modulation symbols. Hence, each pair of modulation symbols are mapped directly to OFDM subcarriers of first antenna while mapping of each pair of symbols to corresponding subcarriers of second antenna are reversely ordered, complex conjugated and signed reversed. The symbols transmitted from two transmitted antennas on every pair of neighboring subcarriers are characterized in as follows

$$X = \begin{bmatrix} x^{(0)}(1) & x^{(1)}(1) \\ x^{(0)}(2) & x^{(1)}(2) \end{bmatrix} = \begin{bmatrix} s_0 & -s_1^* \\ s_1 & s_0^* \end{bmatrix} \begin{matrix} \text{Frequency} \\ \downarrow \text{space} \end{matrix}$$

Where $x^{(p)}(k)$ denotes the symbols transmitted from antenna port ‘p’ on the k^{th} subcarrier. The received symbol can be expressed as follows:

$$Y = Hs + n$$

$$\begin{bmatrix} y_0 \\ y_1 \end{bmatrix} = \frac{1}{\sqrt{2}} \begin{bmatrix} h_{00} & -h_{01} \\ h_{11} & h_{10} \end{bmatrix} \begin{bmatrix} s_0 \\ s_1 \end{bmatrix} + \begin{bmatrix} n_0 \\ n_1 \end{bmatrix}$$

Where h_{ij} , channel response of at symbol ‘i’ transmitted from antenna ‘j’, and ‘n’ is the additive white Gaussian noise.

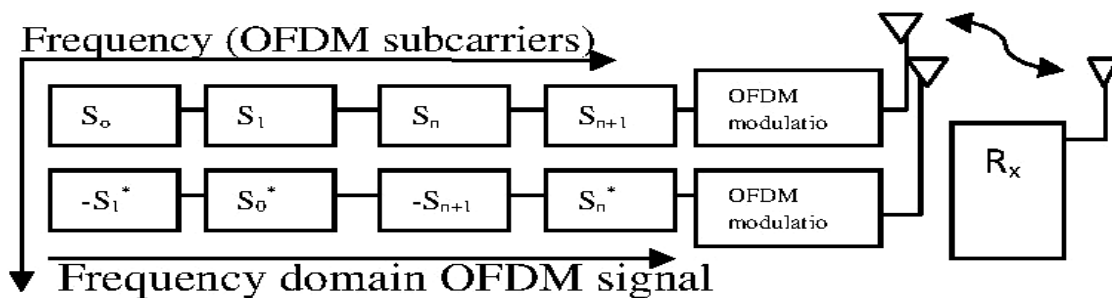

Fig. 2

3. (AMS) scheme for PAPR reduction in (MIMO-OFDM) systems with space–frequency block coding (SFBC)

The key idea of the proposed scheme is keeping the advantage of the SFBC structure to generate some AMSs via combining the signals at different transmit antennas. Specifically, when the proposed scheme is employed in SFBC MIMO OFDM systems with quadrature-amplitude modulation (QAM) For convenience and simplicity, the Altamonte space–frequency block coding (SFBC) is employed in MIMO-OFDM systems in this paper original data sequences at two antennas are partitioned into several pairs of sub blocks, and each pair of sub blocks multiplies by different factors to generate different pair of sub blocks. Then, the obtained new sub blocks are combined to generate AMSs, which keep the structure and the diversity capability of the Altamonte SFBC. Finally, the pair of alternative sequences with the smallest PAPR is chosen to be transmitted if the factors for side information are particularly chosen, the transformed pair of the constellation points corresponds to only one pair of the original constellation points. As a result, the received pair of the constellation points could determine its corresponding original data without SI at the receiver.

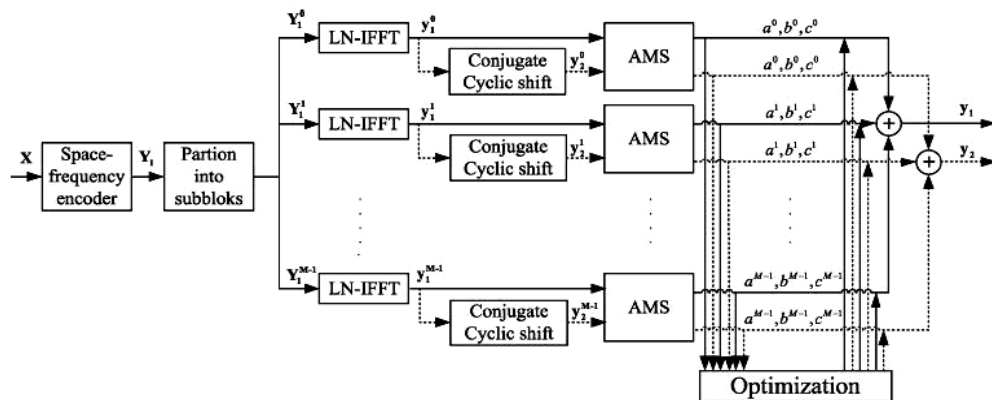

Fig. 3. Block diagram for AMS scheme

For input symbol of N data=1024 and oversampling factor $L = 4$. 16-QAM are employed with $V = 8$ when $\text{Prob}\{\text{PAPR} > \text{PAPR}_0\} = 10^{-4}$, For 16-QAM, compared with the original signals, AMS method with $M = 2$ and $M = 4$ could obtain 3.75 and 4.68-dB PAPR reductions, respectively[1] For the AMS scheme, it takes $n_{\text{mul}} = \text{MLN}/2 \log_2 \text{LN}/2 + \text{MLN}$ complex multiplications and $n_{\text{add}} = \text{MLN} \log_2 \text{LN}/2 + 2\text{MLN}$ complex additions to get $(\mathbf{y}_i^m)^c$, $n_{\text{add}} = 4\text{MLN}$ complex additions to get $2(\mathbf{y}_i^m)^c$, and $n_{\text{add}} = 2\text{MLN}$ complex additions to get \mathbf{y}_i^m , where $i = 1, 2, m = 0, 1, \dots, M - 1$, and $c_m = 1, 2$. Moreover, it takes $n_{\text{add}} = 2(M - 1)\text{LN}$ complex additions to generate each pair of alternative signals It is shown that the number of complex multiplications for the proposed AMS scheme is smaller than that for the PTS scheme; the number of complex additions for the proposed AMS scheme is a little larger than that of the PTS scheme For AMS method BER performance Without SI is the same as that with perfect SI when $\text{BER} < 10^{-2}$. $\text{BER} = 10^{-2}$ and $\text{BER} = 10^{-1}$ when $\text{SNR} = 15$ dB and $\text{SNR} = 20$ dB for 4-QAM and 16-QAM, respectively

3.1 A low-complexity PAPR reduction scheme for SFBC OFDM MIMO systems

As opposed to conventional schemes that require at least two IFFTs, the proposed scheme fully exploits the time-domain signal relationship between the two antennas and only needs one IFFT. The candidate signal pairs of the two antennas are generated in the time-domain, rather than the frequency domain, for complexity reduction by using a variety of time-domain signal properties inherent in SFBC MIMO-OFDM systems this scheme generates candidate signal pairs in time-

domain and fully utilizes signal $X_{1,e}, X_{1,o}, X_{2,o}$ are fed into the candidate signal generating block (CSGB) In particular, the number of complex multiplications and additions required in the

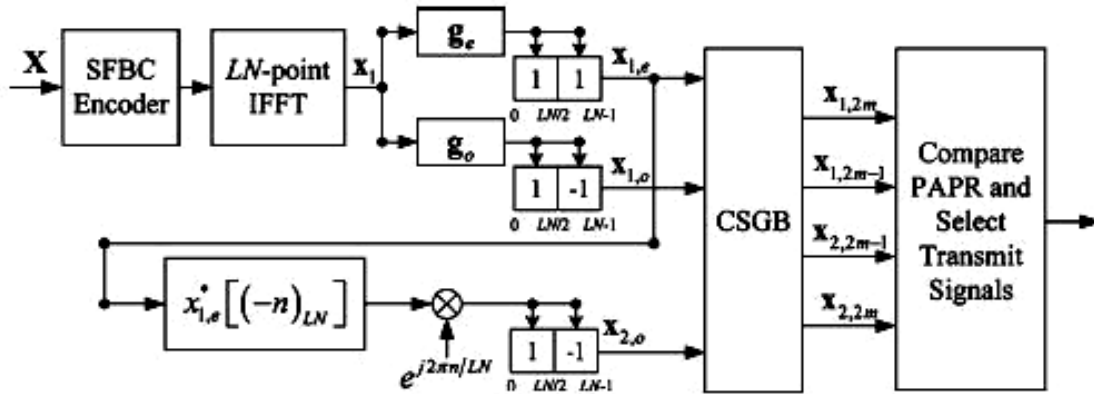
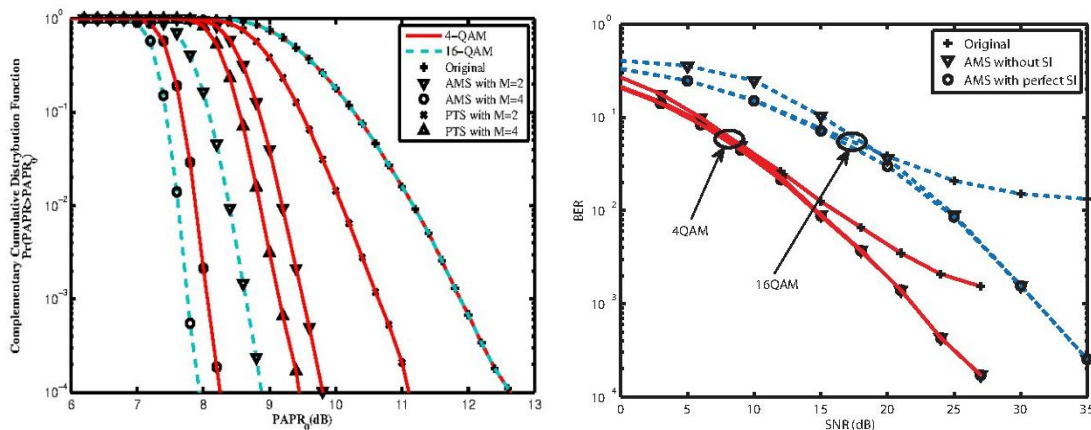

Fig. 4. Architecture of low complexity scheme

proposed scheme is only 4.22% and 11.72%, respectively, to that required in the SLM scheme for $M=32$ for this scheme no of complex additions are $LN \log_2(LN) + LN(2M+1)$ and multiplications are $(LN/2) \log_2(LN) + LN/2(M/2+1)$

4. Simulation Results

In this section, some simulations have been conducted to evaluate the ability of the proposed scheme including the PAPR reduction, computational complexity and BER performance, where OFDM symbols have been randomly generated with $N = 1024$ and the oversampling factor $= 4$. 4-QAM and 16-QAM modulation are employed with $M = 4$ and $M = 8$, respectively. Since PAPR is a random variable, complementary cumulative distribution function (CCDF) is



PAPR reduction of the proposed AMS and conventional PTS schemes with 4-QAM and 16-QAM modulations, respectively. BER performance of the AMS scheme over fading channel without side information and with perfect side information when 4-QAM and 16-QAM modulations are employed, respectively used to describe the statistical properties of the PAPR in SFBC MIMO-OFDM systems.

COMPUTATIONAL COMPLEXITY OF THE AMS AND PTS SCHEMES

	$M = 2$	$M = 4$
AMS	$n_{mul} = 61440$ $(LN \log_2 \frac{LN}{2} + 4LN)$	$n_{mul} = 122880$ $(2LN \log_2 \frac{LN}{2} + 8LN)$
	$n_{add} = 360448$ $(2LN \log_2 \frac{LN}{2} + 66LN)$	$n_{add} = 15671296$ $(4LN \log_2 \frac{LN}{2} + 3782LN)$
PTS	$n_{mul} = 98304$ $(2LN \log_2 LN)$	$n_{mul} = 196608$ $(4LN \log_2 LN)$
	$n_{add} = 327680$ $(4LN \log_2 LN + 32LN)$	$n_{add} = 6684672$ $(8LN \log_2 LN + 1536LN)$

Table 1. Computational Complexity

The PAPR reduction of the AMS method with 4-QAM and 16-QAM modulations, respectively. For comparison, the PAPR reduction performance of the conventional PTS scheme is also shown in Fig. 2 when 4-QAM is employed, where the number of subblocks for the PTS scheme is = 2 and = 4, respectively, and the number of alternative phase rotation factors for each sub block is = 4. Compared with the original OFDM signals, when $\{ > 0 \} = 10^{-4}$, 2.86dB and 4.36dB PAPR reduction are obtained by the AMS scheme with = 2 and = 4 for 4-QAM modulation, respectively. Compared with the original signals, the conventional PTS scheme could provide 1.54dB and 3.15dB PAPR reduction when the number of subblocks is = 2 and = 4, respectively. For 16-QAM modulation, compared with the original signals, it is that the AMS method with = 2 and = 4 could obtain 3.75dB and 4.68dB PAPR reduction, respectively the BER performance of the AMS method with = 4 for 4-QAM and 16-QAM modulations, respectively. The channels between each transmit antenna and receive antenna are modeled as the frequency-selection fading channel with impulse response $h(T)$, and Table I that the AMS scheme achieves better PAPR reduction performance with lower computational complexity, compared with the conventional PTS scheme. Refer to, the AMS scheme without side information could achieve the same BER performance as its with perfect side information when the $< 10^{-2}$. However, the transmitted side information may also be recovered incorrectly at the receiver in practical communications. Consequently, the proposed scheme without side information could obtain better BER performance than that of other schemes with side information transmitted.

5. Conclusions

A Novel AMS scheme was proposed to reduce the PAPR of SFBC MIMO-OFDM signals, which could provide good PAPR reduction with low computational complexity. The improved AMS method without side information for 4-QAM and 16-QAM modulations was also proposed in detail. Simulation results show that the proposed AMS scheme is efficient in achieving good performances in terms of the PAPR reduction and BER.

References

1. Alamouti, S. M. "A simple transmit diversity technique for wireless communications," IEEE Journal on Selected Areas in Communications, vol. 16, no. 8, pp. 1451-1458, Oct. 1998.
2. Cai Li, Tao Jiang, Yang Zhou, and Haibo Li, "A Novel Constellation Reshaping Method for PAPR Reduction of OFDM Signals," IEEE Transactions on Signal Processing, vol. 59, no. 6, pp. 2710-2719, Jun. 2011.
3. Du, Z. N. C. Beaulieu, and J. Zhu, "Selective Time-Domain Filtering for Reduced-Complexity PAPR Reduction in OFDM," IEEE Transactions on Vehicular Technology, vol. 58, no. 3, pp. 1170-1176, Mar. 2009.
4. Ghassemi, and T. A. Gulliver, "A Low-Complexity PTS-Based Radix FFT Method for PAPR

- Reduction in OFDM Systems,” IEEE Transactions on Signal Processing, vol. 56, no. 3, pp. 1161-1166, Mar. 200
5. Jiang, T. and X. Li, “Using Fountain Codes to Control the Peak-to-Average Power Ratio of OFDM Signals,” IEEE Transactions on Vehicular Technology, vol. 59, no. 8, pp. 3779-3885, Oct. 2010.
 6. Jiang T. and G. Zhu, “Nonlinear companding transform for reducing peak-to-average power ratio of ofdm signals,” IEEE Transactions on Broadcasting, vol. 50, no. 3, pp. 342-346, Sept. 2004.
 7. Jiang, T. and G. Zhu, “Complement block coding for reduction in peak-to-average power ratio of ofdm signals,” IEEE Communications Magazine, vol. 43, no. 9, pp. S17-S22, Sept. 2005.
 8. Kim, Y.-J. U.-K. Kwon, D.-Y. Seol, and G.-H. Im, “An Effective PAPR Reduction of SFBC-OFDM for Multinode Cooperative Transmission,” IEEE Signal Processing Letters, vol. 16, no. 11, pp. 925-928, Nov. 2009.
 9. Latinovic, Z. and Y. Bar-Ness, “SFBC MIMO-OFDM peak-to-average power ratio reduction by polyphase interleaving and inversion,” IEEE Communications Letters, vol. 10, no. 4, pp. 266-268, Apr. 2006.
 10. Muta, O. and Y. Akaiwa, “Weighting Factor Estimation Method for Peak Power Reduction Based on Adaptive Flipping of Parity Bits in Turbo-Coded OFDM Systems,” IEEE Transactions on Vehicular Technology, vol. 57, no. 6, pp. 3551-3562, Nov. 2008.
 11. Naeiny, M. F. and F. Marvasti, “Selected Mapping Algorithm for PAPR Reduction of Space-Frequency Coded OFDM Systems without Side Information,” IEEE Transactions on Vehicular Technology, vol. 60, no. 3, pp. 1211-1216, Mar. 2011.
 12. Rodrigues, M. R. D. and I. J. Wassell, “IMD Reduction with SLM and PTS to Improve the Error-Probability Performance of Nonlinearly Distorted OFDM Signals,” IEEE Transactions on Vehicular Technology, vol. 55, no. 2, pp. 537-548, Mar. 2006.
 13. Slimane, S. B. “Reducing the Peak-to-Average Power Ratio of OFDM Signals through Precoding,” IEEE Transactions on Vehicular Technology, vol. 56, no. 2, pp. 686-695, Mar. 2007.
 14. Wang, S.-H. and C.-P. Li, “A Low-Complexity PAPR Reduction Scheme for SFBC MIMO-OFDM Systems,” IEEE Signal Processing Letters, vol. 16, no. 11, pp. 941-944, Nov. 2009.
 15. Zhang, Q. F. Yu, and A. Nallanathan, “Improving Achievable Rates in MPSK Amplify-and-Forward Relay Networks via Clipping,” IEEE Transactions on Vehicular Technology, vol. 59, no. 5, pp. 2133-2137, Jun. 2010.